

FLOOR PLANK INSTALLATION DETAILS

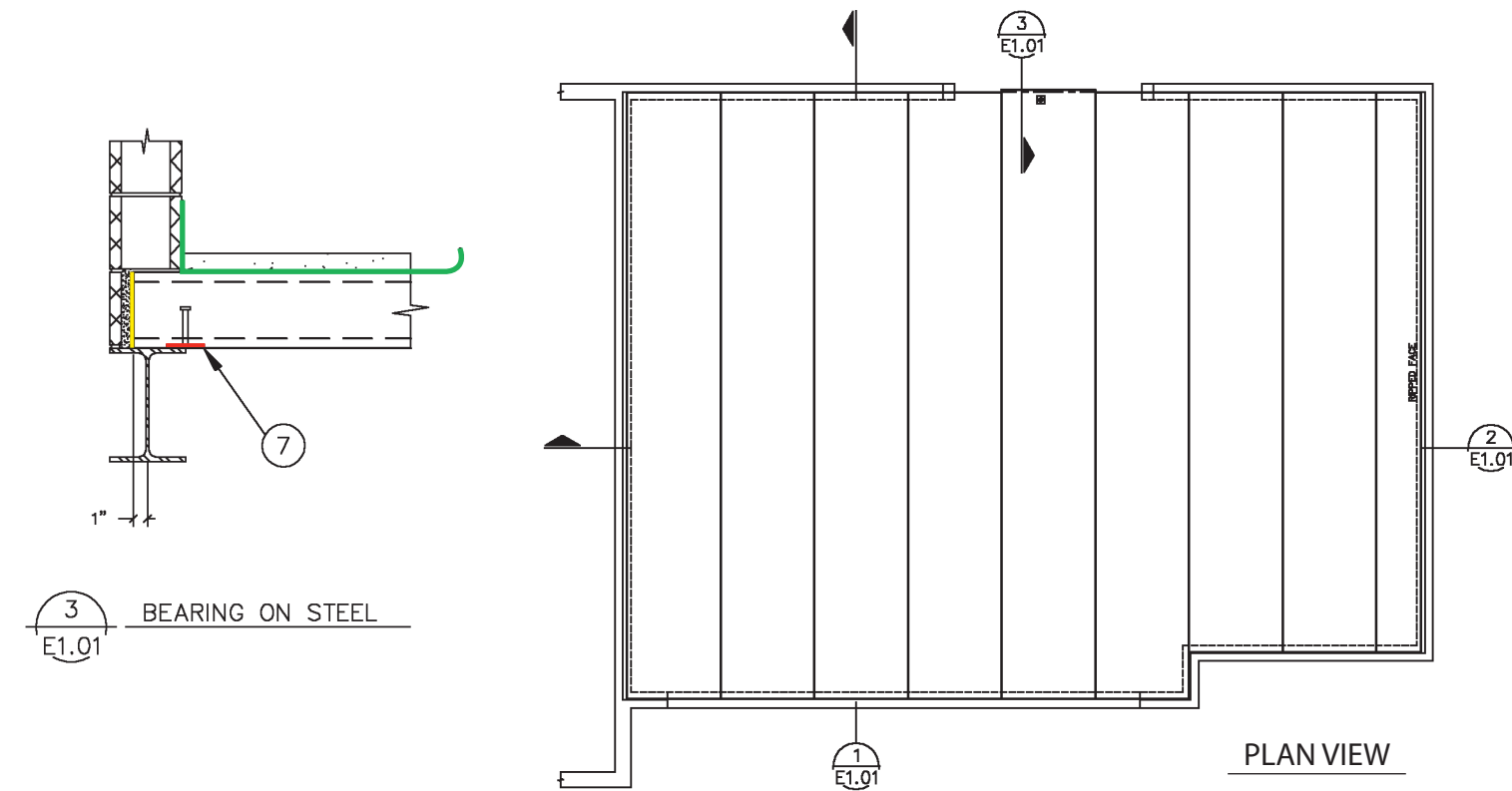

1. Plank length is determined by adding the amount of plank bearing to the inside-to-inside dimension of your bearing walls. The plank bearing surface typically required for concrete and masonry is 4". For masonry bearing, a bond beam is required.
2. A mechanical connection between the precast plank and your structure is required. Shown here are drilled bent bar connections which are provided by Kerkstra Precast. Connections will be shown on Kerkstra Precast shop drawings 2 to 3 weeks after job is awarded.
3. In cold weather areas, insulation should be placed around the entire perimeter between the plank and the wall and at the entrance between the plank and topping edge. Insulation is provided and installed by the home builder.
4. A commercially available water-proofing membrane is highly recommended to be installed (by others) on top of the plank prior to placement of concrete topping. The membrane should be capable of flexibly bridging the insulation and small gaps around the perimeter walls. It should return up the walls and terminate at the top of the topping slab.

The membrane is necessary to prevent water from penetrating the plank, which could cause deterioration of plank reinforcing and concrete in future years. It will also act as a vapor barrier in cold climates where the area below the floor is heated.
5. Quality, high-strength, air-entrained concrete, placed by qualified personnel, is the final important step to your project. Minimum concrete topping thickness is 2", and must be positively sloped to the garage door to ensure drainage and prevent water from ponding on the floor. If interior drains are used, the concrete should be sloped to the drains, and drain fixture detail should be capable of draining moisture from the membrane - which is installed by others. Reinforcing is recommended in the topping, and a concrete sealer should be applied after curing.
6. Additional reinforcing, such as mesh, properly placed in the topping at the door entrance, can minimize the possibility of a crack developing in the topping along the base of your overhead door.
7. At steel beams, plank bearing must extend at least 1" past the beam-web center to prevent beam rotation. A weld plate, or other mechanical connection, is required. This detail will be shown on the shop drawings.
8. Masonry should not be installed above plank-bearing elevation prior to plank erection, as it is highly susceptible to damage during plank erection.
9. Plank keyway joints are grouted by Kerkstra Precast when installed.
10. Round holes for drains can be drilled (by others) after installation, through the center of the plank cores. Allowable diameter of hole to be 1" less than core diameter.

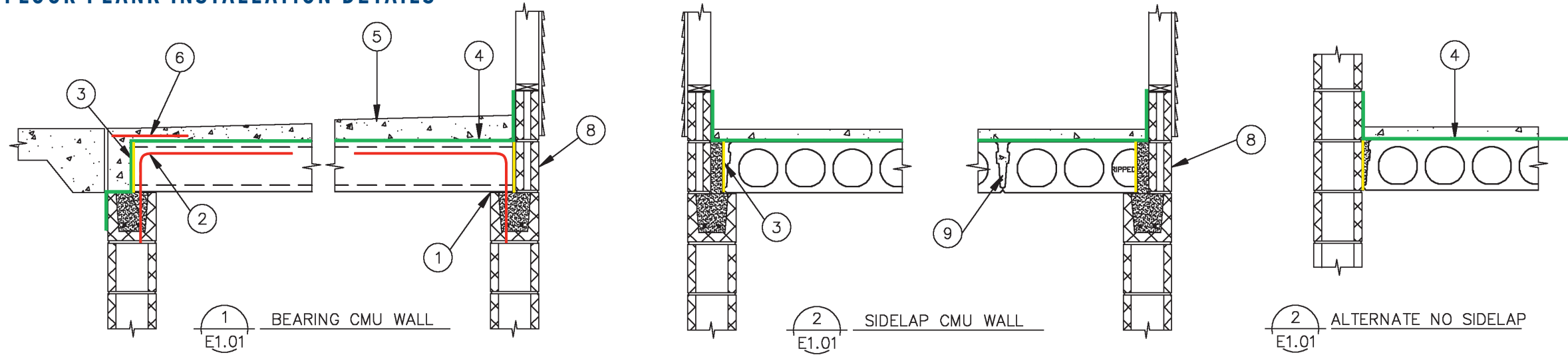
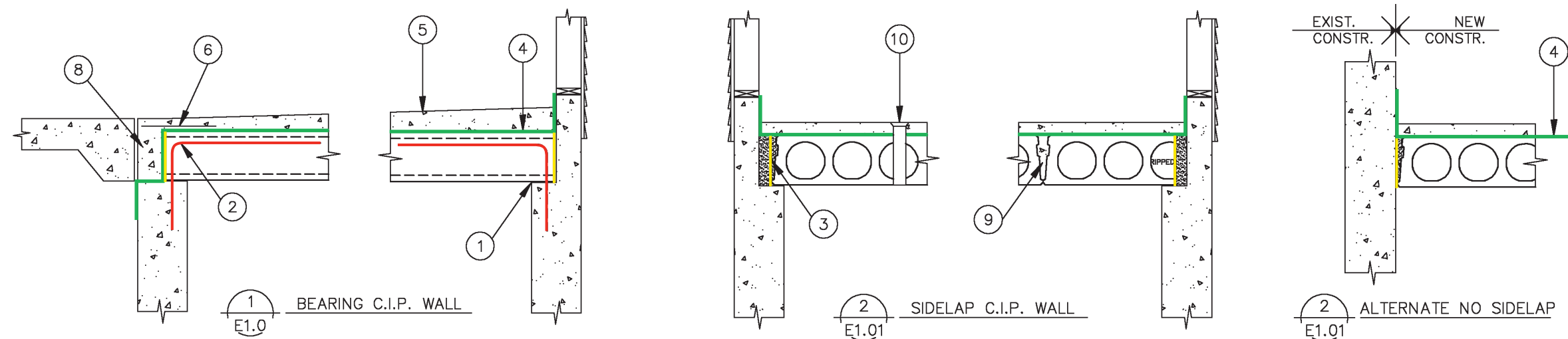

KERKSTRA PRECAST PERFECT FOR:

- > Multi-level garage systems
- > Entire first level floor
- > Complete home systems
- > Balconies, decks, porches

KERKSTRA PRECAST FLOOR PLANK ADVANTAGES:

- > Total planning flexibility
- > Superior sound resistance
- > Perfect for in-floor radiant heat systems
- > All weather installation
- > Excellent fire barrier
- > Low maintenance
- > Exceptional durability

